



Star
Manufacturing
International Inc.

10 Sunnen Drive
St. Louis, MO 63143

Phone: (314) 781-2777
Fax: (314) 781-3636

Installation
and
Operating
Instructions

2M-Y8266 Rev. C 4/23/99

NACHO CHIP and POPCORN WARMER MODELS 12NCPW and 15NCPW



Model 15NCPW



Model 12NCPW



SAFETY SYMBOL



These symbols are intended to alert the user to the presence of important operating and maintenance instructions in the manual accompanying the appliance.

RETAIN THIS MANUAL FOR FUTURE REFERENCE NOTICE

Using any part other than genuine Star factory supplied parts relieves the manufacturer of all liability.

Star reserves the right to change specifications and product design without notice. Such revisions do not entitle the buyer to corresponding changes, improvements, additions or replacements for previously purchased equipment.

Due to periodic changes in designs, methods, procedures, policies and regulations, the specifications contained in this sheet are subject to change without notice. While Star Manufacturing exercises good faith efforts to provide information that is accurate, we are not responsible for errors or omissions in information provided or conclusions reached as a result of using the specifications. By using the information provided, the user assumes all risks in connection with such use.

MAINTENANCE AND REPAIRS

Contact your local authorized service agent for service or required maintenance. Please record the model number, serial number, voltage and purchase date in the area below and have it ready when you call to ensure a faster service.

Model No. _____

Serial No. _____

Voltage _____

Purchase Date _____

Authorized Service Agent

Reference the listing provided with the unit

or

for an updated listing go to:

Website: www.star-mfg.com
E-mail Service@star-mfg.com
Telephone: (800) 807-9054 Local (314) 781-2777

The Star Service Help Desk

Business Hours: 8:00 am to 4:30 p.m. Central Standard Time

Telephone: (800) 807-9054 Local (314) 781-2777

Fax: (800) 396-2677 Local (314) 781-2714

E-mail Parts@star-mfg.com
Service@star-mfg.com
Warranty@star-mfg.com

Website: www.star-mfg.com

Mailing Address: Star Manufacturing International Inc.
10 Sunnen Drive
St. Louis, MO 63143
U.S.A

GENERAL INSTALLATION DATA



CAUTION

This equipment is designed and sold for commercial use only by personnel trained and experienced in its operation and is not sold for consumer use in and around the home nor for use directly by the general public in food service locations. For equipment to be used by the general public, please contact the factory.

VOLTAGE

The warmer is equipped for use on the voltage specified on the nameplate.



CAUTION

DO NOT CONNECT TO ANY OTHER TYPE OF CURRENT OR THE MACHINE WILL BE SERIOUSLY DAMAGED.

GENERAL OPERATING INSTRUCTIONS

This warmer will help build impulse sales when placed on either a front or back counter. When used as a Nacho Warmer and coupled with Star's Nacho Cheese Warmer, you have all the equipment necessary to get into the very profitable Nacho business! Care should be used when loading chips into this merchandiser/warmer to prevent breakage. A stainless steel chute is provided to help control breakage. Serving is accomplished by opening the lexan door and scooping chips or popcorn into an appropriate serving container.

A warmer element is located under the stainless steel bottom of the unit that gently warms the food product. Turn "ON" the side mounted switch to activate this element and the lamp.

CLEANING

For retaining the high luster on the stainless steel, use a non-abrasive standard stainless steel cleaner. Use a damp cloth and warm mild soap solution to clean the glass, aluminum and plastic surfaces.

MAINTENANCE AND REPAIRS

Contact the factory, a service representative or a local service company for service or required maintenance.

THOROUGHLY INSPECT YOUR UNIT ON ARRIVAL

This unit has been tested for proper operation before leaving our plant to insure delivery of your unit in perfect condition. However, there are instances in which the unit may be damaged in transit. In the event you discover any type of damage to your product upon receipt, you must immediately contact the transportation company who delivered the item to you and initiate your claim with same. If this procedure is not followed, it may affect the warranty status of the unit.

LIMITED EQUIPMENT WARRANTY

All workmanship and material in Star products have a one (1) year limited warranty on parts & labor in the United States and Canada. Such warranty is limited to the original purchaser only and shall be effective from the date the equipment is placed in service. Star's obligation under this warranty is limited to the repair of defects without charge, by the factory authorized service agency or one of its sub-agencies. Models that are considered portable (*see below*) should be taken to the closest Star service agency, transportation prepaid.

- > Star will not assume any responsibility for loss of revenue.
- > On all shipments outside the United States and Canada, see International Warranty.
- * The warranty period for the JetStar series six (6) ounce popcorn machines is two (2) years.
- * The warranty period for the Chrome-Max Griddles is five (5) years on the griddle surface. See detailed warranty provided with unit.
- * The warranty period for Teflon/Dura-Tec coatings is one year under normal use and reasonable care. This warranty does not apply if damage occurs to Teflon/Dura-Tec coatings from improper cleaning, maintenance, use of metallic utensils, or abrasive cleaners. This warranty does not apply to the "non-stick" properties of such materials.
- > This warranty does not apply to "Special Products" but to regular catalog items only. Star's warranty on "Special Products" is six (6) months on parts and ninety (90) days on labor.
- > This warranty does not apply to any item that is disassembled or tampered with for any purpose other than repair by a Star Authorized Service Center or the Service Center's sub-agency.
- > This warranty does not apply if damage occurs from improper installation, misuse, wrong voltage, wrong gas or operated contrary to the Installation and Operating instructions.
- > This warranty is not valid on Conveyor Ovens *unless* a "start-up/check-out" has been performed by a Factory Authorized Technician.

PARTS WARRANTY

Parts that are sold to repair out of warranty equipment are warranted for ninety (90) days. The part only is warranted. Labor to replace the part is chargeable to the customer.

SERVICES NOT COVERED BY WARRANTY

- | | |
|--|---|
| 1. Travel time and mileage rendered beyond the 50 mile radius limit | 10. Voltage conversions |
| 2. Mileage and travel time on portable equipment (<i>see below</i>) | 11. Gas conversions |
| 3. Labor to replace such items that can be replaced easily during a daily cleaning routine, ie; removable kettles on fryers, knobs, grease drawers on griddles, etc. | 12. Pilot light adjustment |
| 4. Installation of equipment | 13. Miscellaneous adjustments |
| 5. Damages due to improper installation | 14. Thermostat calibration and by-pass adjustment |
| 6. Damages from abuse or misuse | 15. Resetting of circuit breakers or safety controls or reset buttons |
| 7. Operated contrary to the Operating and Installation Instructions | 16. Replacement of bulbs |
| 8. Cleaning of equipment | 17. Replacement of fuses |
| 9. Seasoning of griddle plates | 18. Repair of damage created during transit, delivery, & installation OR created by acts of God |

PORTABLE EQUIPMENT

Star will not honor service bills that include travel time and mileage charges for servicing any products considered "Portable" including items listed below. These products should be taken to the Service Agency for repair:

- * The Model 510FD Fryer.
- * The Model J4R, 4 oz. Popcorn Machine.
- * The Model 518CMA & 526CMA Cheese Melter.
- * The Model 12MC & 15MC & 18MCP Hot Food Merchandisers.
- * The Model 12NCPW & 15NCPW Nacho Chip/Popcorn Warmer.
- * All Hot Dog Equipment **except Roller Grills & Drawer Bun Warmers.**
- * All Nacho Cheese Warmers **except Model 11WLA Series Nacho Cheese Warmer.**
- * All Condiment Dispensers **except the Model HPDE, & SPDE Series Dispenser.**
- * All Specialty Food Warmers **except Model 130R, 11RW Series, and 11WSA Series.**
- * All QCS/RCS Series Toasters **except Model QCS3 & RCS3 Series.**

ALL:

- * Pop-Up Toasters
- * Butter Dispensers
- * Pretzel Merchandisers
- * Pastry Display Cabinets
- * Nacho Chip Merchandisers
- * Accessories of any kind
- * Sneeze Guards
- * Pizza Ovens
- * Heat Lamps
- * Pumps

The foregoing warranty is in lieu of any and all other warranties expressed or implied and constitutes the entire warranty.

FOR ASSISTANCE

Should you need any assistance regarding the Operation or Maintenance of any Star equipment; write, phone, fax or email our Service Department. In all correspondence mention the Model number and the Serial number of your unit, and the voltage or type of gas you are using.

MATERIAL		FINISH		MODEL NO. 12NCPW/15NCPW		PART NO. SK1235	
DR.B.N. CK.		DATE 5/7/92		TITLE WIRING DIAGRAM			
LIMITS UNLESS OTHERWISE NOTED		STAR MFG. INTERNATIONAL, INC.		LTR		DATE	
FRACTIONS ± 1/64		9325 OLIVE BOULEVARD ST. LOUIS, MO 63132		A		10/29/92	
DECIMALS ± .005		CHANGES		ADDED		15NCPW INFO	
				B.N		DR	

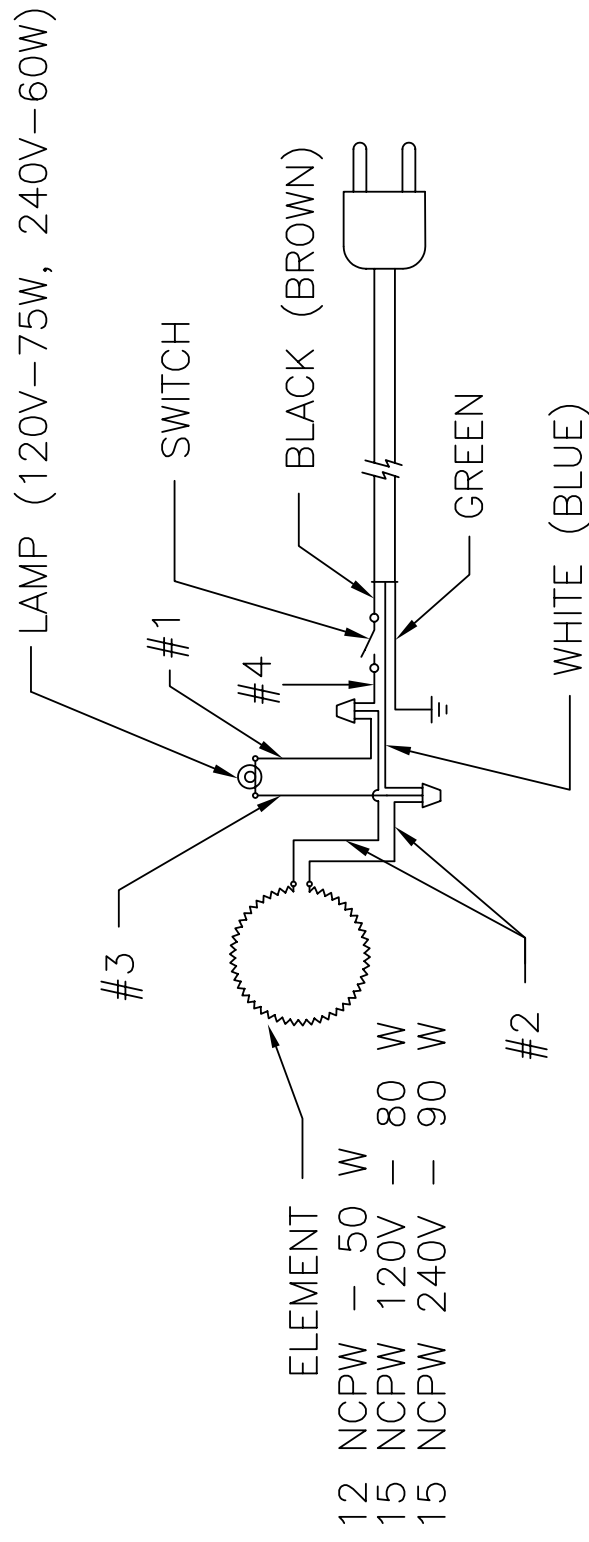

- MODEL 12NCPW, - 120V, 125 WATT
- MODEL 12NCPW, - 240V, 110 WATT
- MODEL 15NCPW, - 120V, 155 WATT
- MODEL 15NCPW, - 240V, 150 WATT

MATERIAL	FINISH	MODEL NO. 230V 12NCPW/15NCPW	PART NO SK1664
DR.M.P. CK. DATE 03-22-99	STAR MFG. INTERNATIONAL, INC. 9325 OLIVE BOULEVARD ST. LOUIS, MO 63132	TITLE WIRING DIAGRAM	
LIMITS UNLESS OTHERWISE NOTED FRACTIONS ± 1/64 DECIMALS ± .005	CHANGES	LTR DATE	CHANGE
			DR

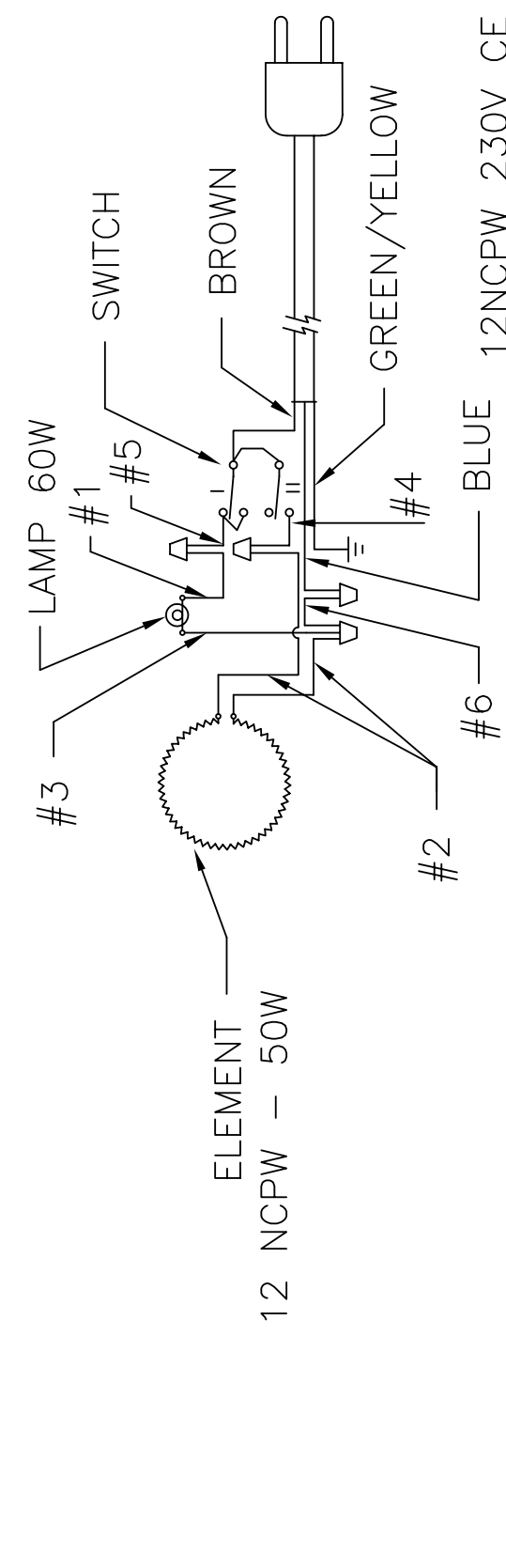
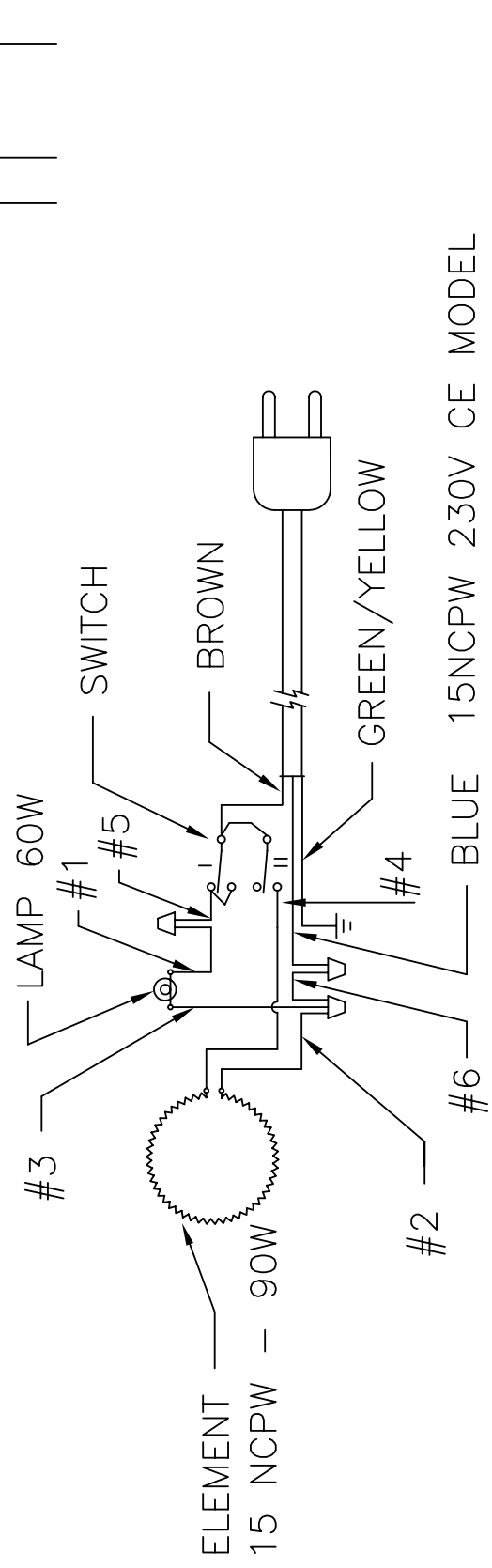

MODEL 12NCPW, - 230V CE, 110 WATT
 MODEL 15NCPW, - 230V CE, 150 WATT

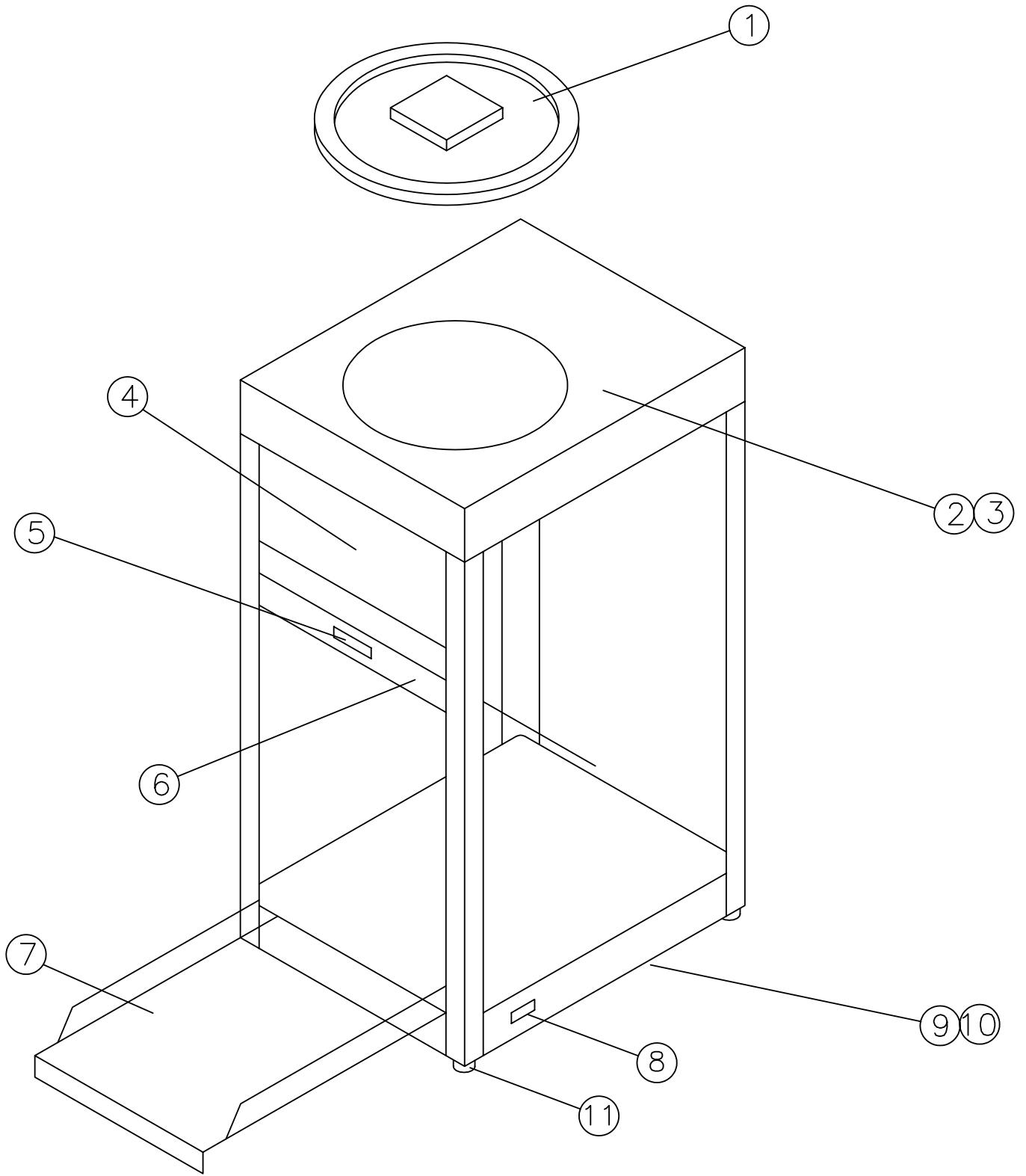

MODEL 12/15 NCPW STAR MANUFACTURING INTERNATIONAL, INC.

SK1388 9/7/95 DR: BN

PARTS LIST

EFFECTIVE 4/23/99 Rev. C

12NCPW/15NCPW 120V/240V /230CE
 MODEL Nacho Chip/Popcorn Warmer

Key Number	Part Number	Number Per Unit	Description	
1	2L-Y8251	1	LID	
2	2S-Y4584	1	LAMP-75W 120V (NOT SHOWN) REFLECTOR FLOOD	
	2S-Y8229	1	LAMP-60W 240V (NOT SHOWN) REFLECTOR FLOOD	
3	2E-Y5636	1	SOCKET-W/31" LEADS (NOT SHOWN)	
4	2M-Y8249	1	SIGN - NACHO CHIPS	12NCPW
	2M-Y8260	1	SIGN - POPCORN	12NCPW
	2M-Y8258	1	SIGN - NACHO CHIPS	15NCPW
	2M-Y8259	1	SIGN - POPCORN	15NCPW
5	2R-Y7330	1	MAGNET CATCH	
6	C5-Y8176	1	SHELF, SMALL	12NCPW
	C4-Y8177	1	SHELF	15NCPW
7	C5-Y8154	1	LOWER DOOR ASSEMBLY	12NCPW
	C5-Y8160	1	LOWER DOOR ASSEMBLY	15NCPW
8	2E-Y6144	1	SWITCH	
9	C4-12004	1	LEAD IN CORD 120V (NOT SHOWN)	
	C4-12014	1	LEAD IN CORD 240V (NOT SHOWN)	
	C4-12020	1	LEAD IN CORD 230CE (NOT SHOWN)	
10	2N-Y4306	1	ELEMENT-50W 120V (NOT SHOWN)	12NCPW
	2N-Y8077	1	ELEMENT-50W 240V (NOT SHOWN)	12NCPW
	2N-Y4380	1	ELEMENT-80W 120V (NOT SHOWN)	15NCPW
	2N-Y4381	1	ELEMENT-90W 240V (NOT SHOWN)	15NCPW
11	2I-H7685	4	FOOT	
	C5-Y8184	1	LAMP SHIELD	
	C5-Y8153	1	LAMP BRACKET	
	C5-Y7725	1	ADHESIVE STRIP	
	C5-Y7724	1	STRIKE	
	2K-7889	1	BUSHING - CORD - 90° (NOT SHOWN)	
	2I-Y4274	1	GASKET (NOT SHOWN)	
	C5-Y8182	1	TOP-PAINTED	12NCPW
	C4-Y8183	1	TOP-PAINTED	15NCPW
			(REPLACEMENT GLASS MUST BE PURCHASED LOCALLY)	
	2Q-Y8156	1	GLASS-BACK (5" x 10")	12NCPW
	2Q-Y8164	2	GLASS-SIDE (13" x 17")	12NCPW
	2Q-Y8163	1	GLASS-FRONT (10" x 17")	12NCPW
	2Q-Y8157	1	GLASS-BACK (8" x 13")	15NCPW
	2Q-Y8165	3	GLASS-SIDES (13" x 20") AND FRONT	15NCPW

IMPORTANT: WHEN ORDERING, SPECIFY VOLTAGE OR TYPE GAS DESIRED
 INCLUDE MODEL AND SERIAL NUMBER

PAGE 1
 OF 1

Some items are included for illustrative purposes only and in certain instances may not be available.



Star Manufacturing International, Inc.